



## SE-5000 Series are widely used in following industrial applications:

Bio-Safe Chest, Laminar Flow Bench, Industrial Vacuum Cleaner, Drying Oven, Respiratory Treatment Equipment, etc. in Electronic Air Circuit System as measuring gauge in monitoring differential pressure in ventilation system.

## Specifications

- Measuring Media: Gas
- Accuracy: 5%
- Maximum pressure resistance: 30 PSI
- Environment Temperature: -6 ~ 50 °C
- Casing Material: FRP & ABS
- Dimensions: diameter: 65.88 mm
- Weight: 170 g

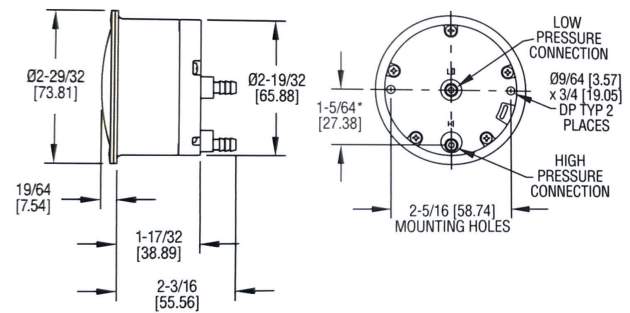

## Pressure Range

Model Number	Range Inches of Water	Model Number	Range PSI	Model Number	Range MM of Water
SE5000-0	0-0.5	SE5205	0-5	SE5000-25MM	0-25
SE5001	0-1.0	SE5210	0-10	SE5000-50MM	0-50
SE5002	0-2.0	SE5215	0-15	SE5000-100MM	0-100
SE5003	0-3.0			Model Number	Range Pa
SE5005	0-5.0			SE5000-125Pa	0-125
SE5010	0-10			SE5000-250Pa	0-250
SE5020	0-20			SE5000-500Pa	0-500
SE5040	0-40			Model Number	Range KPa
SE5060	0-60			SE5000-1KPa	0-1
SE5100	0-100			SE5000-3KPa	0-3